



MAREN
Balers & Shredders
Building customer loyalty since 1962.

Floor Sweep Shredder

***The easiest and quickest way
to dispose of paper scrap,
cut-offs, signatures
and packing
materials from
your production
area.***

**Easy
Quiet
Fast**



***The ONE SOURCE
for innovation for your
Waste Management System.***

MAREN FLOOR SWEEP SHREDDER

SPECIFICATIONS: All dimensions are in inches

MODEL	HP	THROAT WIDTH	A	B	C	D	E	APPROX. WEIGHT
24	20	24"	24"	10"	30"	28"	51"	1700 lbs.
30	25	30"	30"	13"	36"	34"	57"	1800 lbs.
36	30	36"	36"	16"	42"	40"	63"	1900 lbs.

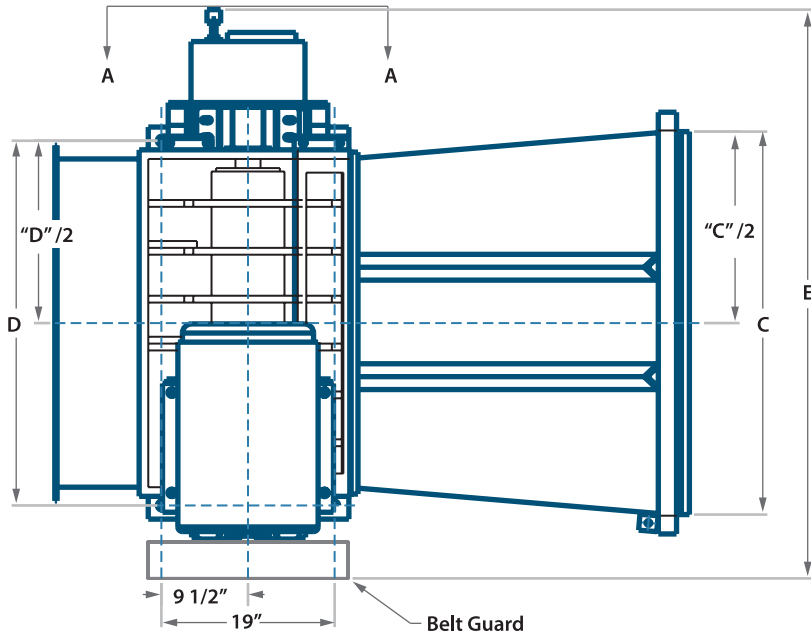

Maren Floor Sweep Shredders can easily adapt to Scrap Belt / Airveyor discharges

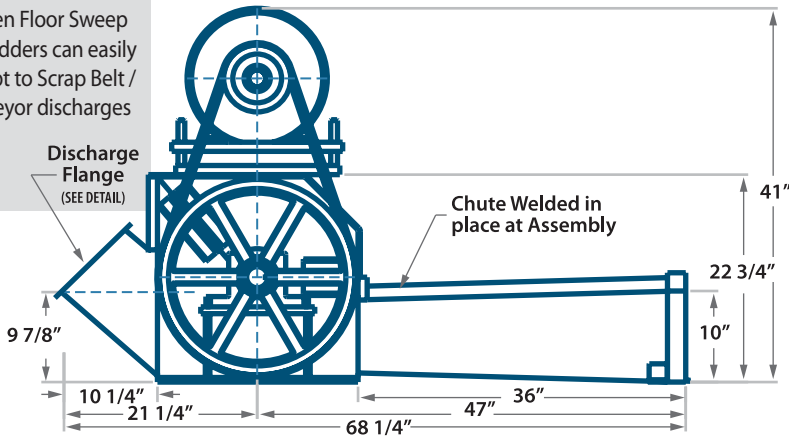

Ends double-handling of scrap while adding extra capacity to your existing air conveyor system.

Get die-cuts and cut-offs out of your production area fast. Just push them into the floor level in-feed chute of the Maren Floor Sweep Shredder. Shredder quickly reduces scrap into easily handled small pieces and passes them directly into the plant air conveying system. That's all there is to it. Maren Floor Sweep Shredders do the job quietly, quickly, efficiently and have features you can't find on other shredders.

All Maren Shredders are ruggedly built... equipped with T.E.F.C. motors, heavy-duty feed belt drive and guard to provide longest service life with least maintenance. Capacities up to 6000 lbs. per hour.

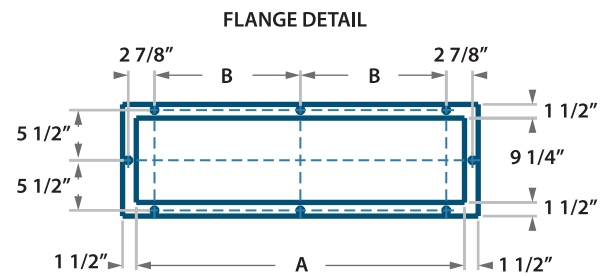

QUIET

- Low RPM
- No vibration
- No special foundation required.
- Exclusive blade design pierces and cuts waste.

FAST

- Shredded material breezes through air conveyor system without danger of clogging.
- Actually increases your existing air-conveyor capacities.

EFFICIENT

- No dust
- Easy blade replacement
- Handles corrugated, packing materials, signatures, etc.
- Simple installation
- Adapts to any air conveying system



MAREN
Balers & Shredders
Building customer loyalty since 1962.